

## Design, Construction and Evaluation of a Cylinder Lawn Mower

<sup>1</sup>P. Okokpujie Imhade, <sup>2</sup>O. Okokpujie Kennedy, <sup>1</sup>O. Ajayi Oluseyi,

<sup>1</sup>Azeta Joseph and <sup>3</sup>N. Nwoke Obinna

<sup>1</sup>Department of Mechanical Engineering, Covenant University,  
P.M.B 1023, Ota, Ogun State, Nigeria

<sup>2</sup>Department of Electrical and Information Engineering,  
Covenant University, Ota, Ogun State, Nigeria

<sup>3</sup>Department of Mechanical Engineering Technology,  
Akanu Ibiam Federal Polytechnic, Unwana, Ebonyi State, Nigeria

---

**Abstract:** A manually operated mechanical machine for cutting grass was design, fabricated and tested. The machine was design with an internal gear system which transfers the torque to the mower mechanism. The machine's performance test evaluation was conducted in delta state sports stadium Asaba. Area of grass cut 2.1 m<sup>2</sup>, desired height of cut 20 m, time taken 2 min, area of grass cut to desired height 1.92 m<sup>2</sup> which gave the cutting efficiency of the cylinder lawn mower 91% with 0.244 KN human effort were obtained. The cutting effectiveness was achieved with a total power of 579.6 W at a rotary speed of 135 rpm of shaft. Its friendly to the environment because it does not emits carbon monoxide into the environment and the noise level is drastically reduced. The machine is considered highly efficient and is readily adaptable to different cutting conditions.

**Key words:** Lawn mower, cylinder mower, shaft, cutting efficiency, Nigeria

---

### INTRODUCTION

A lawn mower is a machine that uses a revolving blade or blades to cut a lawn at an even height. Lawn mower employing a blade that rotates about a vertical axis is known as rotary mower while those employing a blade assembly that rotates about a horizontal axis are known as cylinder or reel mowers. Many design have been made, each suited to a particular propose. The smallest types, pushed by a human are suitable for small residential lawn's and garden while larger, self-contained, ride on powers are suitable for large lawns and the largest, malt-gang mower pulled behind a tractor are designed for large operating expense of grass such as golf course and municipal parks. The type of mower considered in this study is a manually operated lawn mower. Putting into consideration of horticultural engineering one emphatically say the lawn cutting had been with man since time immoral although during this time, cutlass was mostly used for practice the vital intents (factors) are the cutting force that is the force applied and the sharpness of the cutlass made of metal as a follow up from sharpened stone earlier used by man as tools which then could result to a great loss of energy beside time wasted. On the long run, during the industrial revolution, some bigger cutters were fabricated and this became mobile driven by horse mainly for mechanized farming and

to reduce labour. The discovery of iron ore made it interesting for the engineer to fabricate many cutting tools used on farm and lawn. More so, the development of steam engine was a great breakthrough which opened the door for smaller engines to drive cutter for grass cutting both on farm and on the field. Basically, there was no provision available for grass mowing it was the development of bush clearing and hay harvesting that brought in grass mowing that is they hay harvester was modified and develop into lawn mower (John, 2012).

The reel (cylindrical) mowers seem to be better. Made of blades on a revolving cylinder, they achieve clean cut by scissors action. As the mower moves forward, the rotating blades come in contact with a stationary bar called the bed knife and placed parallel to the ground. Grass is held by the shearing action of the reel blades against the bed knife. In selecting a mower the first consideration is the mechanism on the cutting principles. That is how effective and reliable the cutting techniques. One of the two methods the impact cutting or shearing (scissoring) is used the modern days. The impact cutting or shearing is associated with its merit and demerits, scissoring which is otherwise known as the shearing action is most often represented by the cylinder lawn mower to successfully cut the blades should run very close to one another and of cause it does not need to touch. Mower can be classified into five different groups,

namely. Cylinder mower (it includes the lawn mowers and gang mowers), rotating disc mowers, reciprocating knife mowers, flail mowers, nylon cord mowers. A propane mower is also quieter than gasoline and many other options for a customer to select (Grove, 1968). So far, it can be seen that there are different sources of power which is used to drive them and also it has been seen that the various types of lawn mower has some advantages due to the source of power to drive the blades.

Dakogol stated that in farming practice, removal of vegetation up to 100 mm below ground level is very important. Clearing operation is also done in gardens and surroundings of premises. This involves four different methods which are employed for land clearing, via, physical uprooting of trees and vegetation, cutting the vegetation at ground level and collecting the same for burning or allowed to decay, crushing down the vegetation or ploughing and mixing in the vegetation to a soil depth of about 200 mm (Ireson, 1964). Designed and fabricated solar charged lawn mower. The machine was dependent on weather condition since the battery would be charged using photovoltaic panel (solar panel). The common disadvantage was that the engine runs down easily and the cost of production was high for an average individual to purchase. Victor and Verns (2003) designed and developed a power operated rotary weeder for wet land paddy. The complex nature of the machine makes its maintenance and operation difficult for the peasant farmers. The type of cut desired from a lawn mower determines the type to drive the lawn is the paramount concern of the designer in order to reduce cost and optimize benefit. It is now recommended that an electric motor powered lawn mower will be more economical to use since the source of power is cheap to get and install on the lawn for use.

This research focus on design and construction of a lawn mower to provide alternative mode of cutting grass on our homes and offices and also driven towards the realization of low carbon economy to mitigate global warming effects.

This type of mower does not depend on fuel or electricity for its operation since it is manually operated. The system of cutting is a scissors like action whereby the grasses are trapped between the cutter that is cylindrical cutter and stationary blade. The cylindrical cutter rotates and is drawn across the stationary blade causing a cutting action. The efficiency of this machine depends on the number of blades arranged on the cylindrical shaped disc and the gear ratio. The more the blade the more cut they make per meter and the finer the cut. The blade varies from 3-12 but in this project 6 blade were used. The ratio between the cylinder and the wheel will also affect the number of cut per meter because it determines the number of revolution made per second by the cylinder cutter.

The basic aim of this project is to develop a lawn mower to cut grass effortlessly and to enable a carpet surface cut of grass in our stadium environment which will help us to check gully. The specific objectives of designing this machine includes:

- To enable the environment to have a carpet surface cut of grass
- To save our grass men from the stress of using cutlass or hoes to cut grasses
- The manually operated lawn mower will reduce danger in operation such as electric shock if powered by electricity and reducing cost of fuel for running the mower
- To see how the pollutants generated by the gasoline lawn mower engine can be eradicated by using manually operated lawn mower

## **MATERIALS AND METHODS**

This study research consists of two major components or parts the electric motor and the base. The manufacturing processes used in the construction of this paper are as follows welding, fabrication and assembly. In the fabrication process the handle was constructed the frame which is used to hold the electric motor mounted on the base was also constructed. The mounting bracket and champs were also constructed out of mild steel so they could be easily bent into place. Holes were drilled for clearance of ¼ inch standard hardware with a small drill press. Then removed the sharp edges with a bench grinder and cleaned the part. All metals parts were then painted to protect them from corrosion. The equipment or tools used for the fabrication process are angle bar, bench grinder, drill press, saw blade and tape. One shaft was used in the construction of this study which receives the power transmitted through the belt from the electric motor and then transmits torque which is now used for cutting. The blades for cutting are attached to the shaft by means of welding and bolt (Legge, 1970).

After proper mounting of shaft the electric motor was assembled to the frame on top of the base. Pulleys and belt were also properly assembled and adequate centre distance was given in order for proper tensioning of the belt and also for adequate delivery of power to the shaft. The belt was properly fixed to the pulleys in away to avoid slippage which can damage the belt and also reduce power being delivery.

After fabrication and assembly the necessary joint needed to be welded were welded the bracket, cutter and frame were mounted and welded. The frame, handle for pushing was also welded to the base of the lawn. Tongue, electrode and electric arc machine were equipment and machine used for the welding of this project.

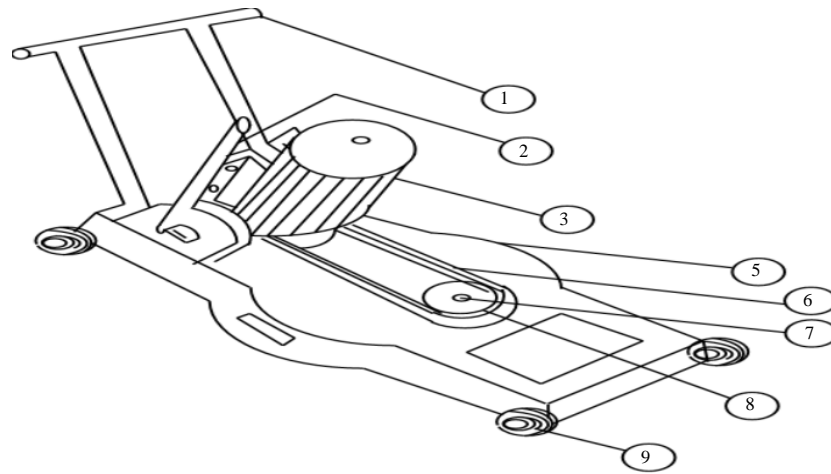

Fig. 1: Isometric view of the lawn mower

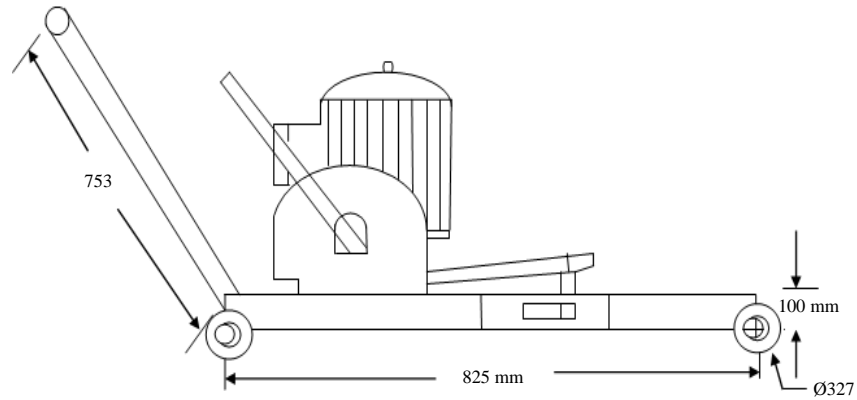

Fig. 2: Side view of the lawn mower

The hand wheel supports the front frame. It is made of rubber and energy losses due to friction is very low, compared to other types of hand wheel. Capacity of lawn mower: the lawn mower was deigned with the capacity to cut the grasses with speed and finely the electric motor has a capacity of 2 horse power to drive the shaft (Wallmart, 2011).

**Design concept:** Figure 1 and 2 show the isometric view, side view and the component of the lawn mower and Table 1 gives the component parts, respectively.

**Design theory:** The mechanical power, P available from any electric motor can be expressed as:

$$P = \frac{2\pi NT}{60} \quad (1)$$

Where:

- N = Speed of the motor (rpm)
- T = Torque developed (Nm)

Table 1: Component part of the lawn mower

Items	QTY
Handle	1
Adjuster	1
Electric motor	3
Blade	1
Base	1
Belt	1
Shaft	1
Pulley	1
Wheel	1

$$T = \frac{60P}{2\pi N} = 9.55PNm/\pi$$

If the gross output of the motor of an induction motor is  $P_m$  and its speed is N rpm then gross torque T developed is given by:

$$T_g = \frac{9.55P_m Nm}{N} \quad (2)$$

Similarly,  $T_{sh} = 9.55 P_{out}Nm/N$  since win age and friction loss is small  $T_g = T_{sh}$ . This assumption hardly leads to any significant error.

**Rotor output:** If  $T_g$  Newton meter is the gross torque developed and  $N$  rpm is the speed of the motor then:

$$\text{Gross rotor output} = \frac{27\pi NT_g}{60} \text{ W} \quad (3)$$

If there were no copper losses in the rotor, the output would equal the input and the rotor would run at synchronous speed  $N_s$ . Gross rotor output =  $27\pi N_s T_g / 60$  watts:

$$\text{Rotor Cu loss} = \text{Rotor input} - \text{Rotor output} = \frac{27\pi T_g (N_s - N)}{60} \quad (4)$$

$$\text{Rotor Cu loss} = \frac{NS - N}{N} = S$$

Rotor input, Rotor Cu loss =  $S \times$  rotor input:

$$\begin{aligned} \text{Gross rotor output, Pin} &= \text{Rotor input} - \text{rotor Cu loss} \\ &= \text{Rotor input} - S \times \text{rotor input, Pin} = \text{Rotor input} (1-S): \end{aligned}$$

$$\frac{\text{Gross rotor output}}{\text{Rotor input}} = 1-S = \frac{N}{N_s}$$

$$\begin{aligned} \text{Rotor-Cu loss} &= S \\ \text{Gross rotor output} &= 1-S \end{aligned}$$

It is clear that if the input power to rotor is  $P$  then  $SP$  is lost as rotor Cu loss and the remaining  $(1-S)P$  is converted into mechanical power. Consequently, induction motor operating at high slip has poor efficiency:

$$\frac{\text{Gross rotor output}}{\text{Rotor input}} = 1 - S$$

If the stator losses as well as friction and wind age losses are neglected. Then:

$$\begin{aligned} \text{Gross rotor output} &= \text{Useful output} \\ \text{Rotor input} &= \text{Stator input} \\ \therefore \text{Useful output} &= 1-S = \text{Efficiency} \\ \text{Stator input} & \end{aligned}$$

Hence, the approximate efficiency of an induction motor is  $1-S$ . Thus, if the slip of an induction motor is 0.125 then its approximate efficiency is  $1-0.125 = 0.875$  or 87.5%.

Table 2: Area of the grasses taken and the corresponding force

Area (X) <sup>2</sup>	Force (N)
0.86×105	54
0.26×105	58
0.46×105	41
0.34×105	37
0.38×105	30
0.23×105	24

Table 3: Sampling these areas of cut on grass land in turn, we obtained the following

Sample	No. of grasses
1	32
2	32
3	30
4	28
5	27
6	31

$$\text{Average} = 32+32+30+28+27+31 = 180/6 = 30$$

**Induction motor torque equation:** The gross torque  $T_g$  developed by an induction motor is given by:

$$T_g = \frac{\text{Rotor Input}}{2\pi N_s} = \frac{60 \times \text{rotor input}}{2\pi N_s} \quad (5)$$

Now:

$$\text{Rotor input} = \frac{\text{Rotor Cu loss}}{S} = \frac{3(T_2)^2 R_2}{S}$$

Using running conditions:

$$T_2 = \frac{SE_2}{\sqrt{R_2^2 + (SX_2)^2}} = \frac{SKE}{\sqrt{R_2^2 + (SX_2)^2}} \quad (6)$$

Where:

$$K = \text{Transformation ratio} = \frac{\text{Rotor turns/Phase}}{\text{Stator turns/Phase}} \quad (7)$$

Since, the cylinder contains 6 cutter along its circumference then they area at  $3600 = 600$  to each other's. Therefore, the length of the stroke of the cutter,  $r = 145$  mm:

$$L = \frac{60}{360} \times 2\pi r = 152 \text{ mm} \quad (8)$$

To calculate the area of cuts, we have equally spaced an angle which calculated  $L$  as follows. This is:

$$A = L \times \frac{1}{3} \times 360, A = 19258.4 \text{ mm}^2 \quad (9)$$

From our experiment in determination of shear stress of grass and taking elephant grass for the experiment Table 2 shows the area of the grasses taken and the corresponding force. And Table 2 and 3 show the sampling areas of cut on grass land. Size and weight limitation. Power transmitted from the previous calculation:

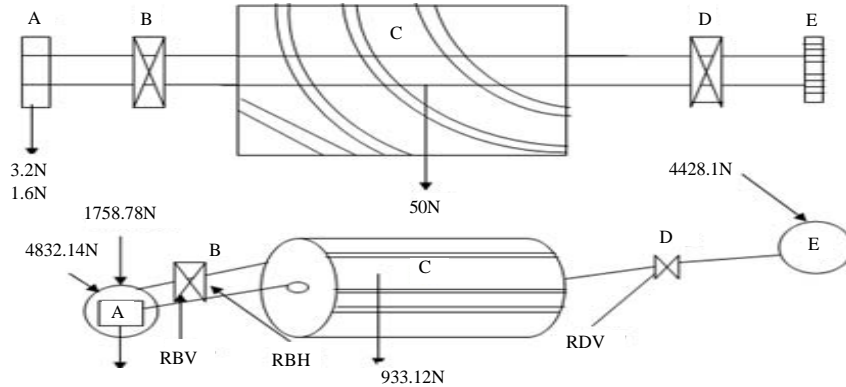

Fig. 3: The cylindrical cutter shaft is loaded

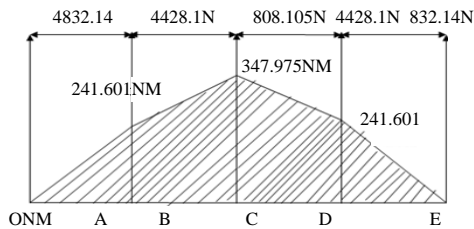

Fig. 4: The bending moment diagram of the horizontal force

$$\text{Torque} = Tw \tag{10}$$

Where:

$$W = \text{Angular velocity in rad/s} = 42.85 \text{ rad/sec}$$

$$P = 135.34 \times 42.85 = 5797.6 \text{ w}$$

**Shaft design:** A shaft is a rotating machine element which is used to transmit power from one place to another. The shaft used in the construction of the machine are the front shaft and the cylindrical cutter shaft out of these shaft, it is only the cylindrical cutter shaft that is critically loaded and therefore if its diameter can be determined, then the same can be used for the front shafts for economic production. The cylindrical cutter is loaded as shown in Fig. 3.

A and E = are the pinion each weighting 3.2N and subjected to a jut of 135.3N from the idler gear as calculated. The tangential force on the pinion is 4832.14N B and D is the bearing which supports the shaft on the frame. The reaction here are to be determine later At C is the cutter in cylindrical cutter with blade having a total weight of 50N.

There also force due to cutting action on these blades and the dictionary cutter. This force has been calculated as is equal to 933.12N. Force is at an angle of 60° C to the vertical plane as shown in Fig. 4.

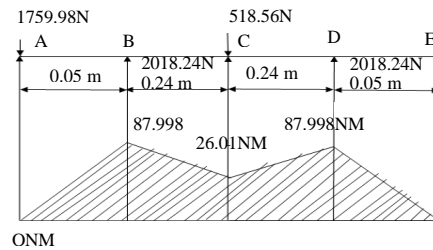

Fig. 5: The bending moment diagram of the vertical force

Taking fix as sum of the force acting along the horizontal we have:  
 $= 0 = D 4832.14 - RBH - 14 \cdot 933.12 \sin 60^\circ - RDH = 4832.14 = 0$   
 $RBH + RDH = 4832.14 + 14 \cdot 933.12 \sin 60^\circ = 9664.28 - 808.105 = 8856.175 \text{ N.}$   
 Taking moment of force about B  
 $MBH = 0 = D 4832.14 (0.05) + 933.12 \sin 60^\circ (0.24) + RDH (0.48) - 4832.14 (0.53) = 0$   
 $241.607 + 193.9452 + rdh (0.48) - 2561.0342 = 0$   
 $RDH (0.48) = 2561.0342 - 241.607 - 193.9482 (0.48)$   
 $RDH = 2125.4842$   
 $RDH = 2125.484 = 4428.1 \text{ N} = 0.48$   
 But  $RBH + RDH = 8856.175$   
 Therefore  $RBH = 8856.175 - 4428.1 = 4428.075 \text{ N.}$   
 Taking sum of the force along the vertical axis, we have:  
 $FY = 0 = D 3.2 - RBV + 50 + 933.12 \cos 60^\circ - RDV + 3.2 + 1756.7 + 1756.67 = 0$   
 $RBV + RDV = 3569 + 466.56 = 4035.56$   
 Taking moment about B  
 $MBr = -(1756.76 + 3.2(0.05)) = 933.12$   
 $\cos 60^\circ (0.24) + 50(0.24) - RBV(0.48) + 1756.70 + 3.2 (0.53) = 0$   
 $RDV (0.48) = -87.998 + 111.974 + 12 + 932.779 = 968.755$   
 $RDV = 968.755 = 2018.24 \text{ N} \cdot 0.48$   
 But  $RBV + RDV = 4036.48$   
 $RBV = 4036.48 - 2018.24 = 2018.24 \text{ N}$

This result is correct because by symmetry the force at B (both vertical and horizontal more than must be equal to that of D (both vertical and horizontal, respectively) (Fig. 5).

To determining the point on which the greatest bending is acting on using Fig. 2:  
 Between  $ABM = 4832.14 \times 0.05$   
 $M = 0$  and  $4832.14 \times 0.5 = 241.607 \text{ Nm}$

Between B and CM = 4832.14x-44281 (X-0.05) = 0

Where x = 0.29

= 4832.14 (0.29)-4428.1 (0.24)

= 1410.7206-1062.744 = 347.976 Nm

Between C and Dm = 4832.14n-4428.1 (x-0.24)

= 808.015 (x -0.29) 0.29 x 0.53

P = 4832.14 (0.53) = 4428.1 (0.48)-808.108 (0.24)

= 241.601

Between D and E-N = 4832.14x -4428.1 (x-0.05)

808.105 (x-0.29)-4428.1 (x-0.53)

Where x = 0.58

M = 4832.14 (0.58-4428 (0.53))-808.105 (0.29)-4428.1 (0.05)

= 2802.6412 = 2346.893-38048-221.408 = ONM

**For vertical moment:**

Bending moment between A and B is given by:

M = 1759.96 = 0 where x = 0.05

Note, x is the pint use are considering

At D, M = 0, at BM = 1759.96 x 0.05

= 87.998Nm

Between B and C

M = 1759.96 x -2018.24 (x-0.05) where x = 0.29

= 1759.96 (0.29-2018)-(0.24)

= 26.0108Nm

Between C and D

M = 1759.96x-2018.24 (x-0.05)+516.56 (x-0.29)

= 0.53

= 1759 (0.053)-2018.24 (0.24)+516/56 (0.24)

= 932.7788-968.7552+123.9744

= 87.998Nm

Between D and E

= 1756.96 201824 (x-0.05)+516.56 (x-0.19)-2018 (x-0.58)

2018 (0.53)-(0.29)-2018 (0.05)

1020.7768-1069.6672+149.8024-1000.912 = ONM

Moment at B or D

$$= \sqrt{Vb^2 + mhb^2} = \sqrt{7.9982^2 + 241.60^2} \tag{11}$$

$$= 257.128Nm$$

Moment at C:

$$= \sqrt{Vb^2 + mhb^2} = 26.0108 + 347.9762$$

$$= 384.947 \mu m$$

This shows that the largest bending moment occurs at point C. Now to calculate the diameter of the shaft. We use the equation (Imhade *et al.*, 2016):

$$D^3 = \frac{32Mc}{\pi\sigma_w} \tag{12}$$

Where:

$$\sigma_w = \frac{\text{Ultimate tensile stress}}{\text{Factor of safety}} = \frac{u.t.s}{f.s} \tag{13}$$

$$\sigma_w = 116.7MN/m^2$$

Therefore,  $D^3 = 32 \times 348.947 / 3.142 \times 116.7 \times 10^6$ ,  $D = 30$  mm.

**Belt calculation**

**Length of belt:** The length of the belt can be determined by using the equation:

$$L = 2a + \frac{r_1 + r_2}{a} \tag{14}$$

Where:

L = Length of belt

a = Centre distance

r<sub>1</sub> = Diameter of small pulley

r<sub>2</sub> = Diameter of big pulley

$$L = 2a + \frac{r_1 + r_2}{2} + \frac{r_1 + r_2}{2} \times \frac{1}{a} \tag{15}$$

Determination of angle of wrap of small pulley is given as:

$\Theta = 180 - 2\alpha$

Given that,

L = ?

A = 0.122 m; r<sub>1</sub> = 0.8 m = 0.8/2 = 0.4 m

r<sub>2</sub> = 1.15 m = 1.15/2 = 0.57 m angle of wrap of smaller pulley

$$\theta = 180 - 2\alpha = \sin^{-1} \frac{(0.4 - 0.575)}{a} = 82.61 \tag{16}$$

$$\theta = 180 - 2(2 \times 82.61) = 14.78^\circ$$

Length of belt:

$$L = 2a + \frac{r_1 + r_2}{a}$$

L = 2x0.122+π(0.975)/2+(0.175)<sup>2</sup>x1/0.122

L = 1.7756+0.2510

L = 2.03 m

**RESULTS AND DISCUSSION**

The performance of the machine was evaluated through a field test. The lawn mower uses multiple cutting blades arranged in form of a cylinder which is turned by a gear connected to the wheels. The act of pushing the machine makes the cylinder revolve. As the mower moves, the rotating blades slice the grass against a stationary cutting blade called the bed knife in a scissor action. The result obtain are has follows area of grass cut = 2.1 m<sup>2</sup>; Desired height of cut = 20 m time taken = 2 min area of grass cut to desired height = 1.92 m<sup>2</sup>. Cutting efficiency of the cylinder lawn mower = (1.92/2.1)x100 = 91%. From Fig. 6, it can be seen that after the first force use in pushing the mower as soon as the mower start moving it turned by a belt connected to the wheels and the shaft rotate which also course the rotating blades slice the grass against a stationary cutting blade and the force keep reducing when the cylinder lawn mower is in motion that shows that even has it is manually operated the human effort needed is not much (Fig. 7).

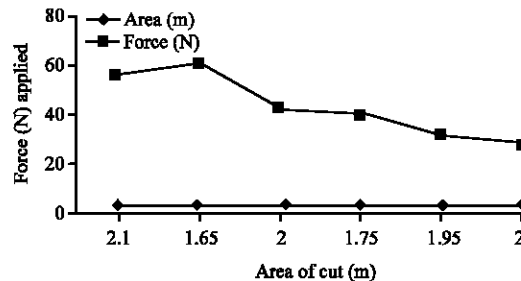

Fig. 6: Area of cut (m) vs. force (N) applied

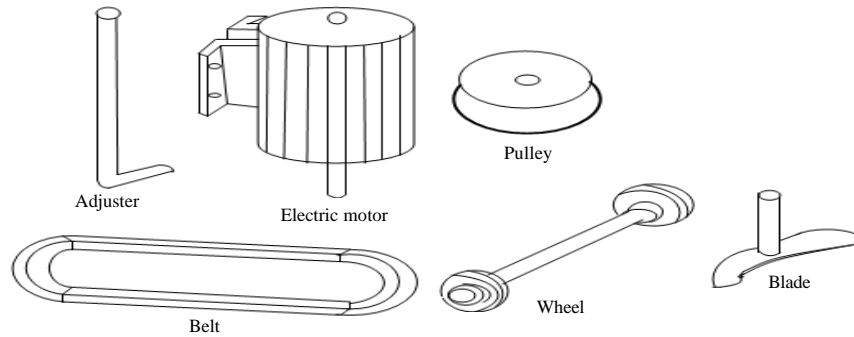

Fig. 7: Components drawing of the lawn mower

### CONCLUSION

The cylinder lawn mower was design, fabricated and tested. This has electric motor but powered by the operator. Test revealed that, higher grass cutting efficiency of 91% is obtained when the lawn is dry before mowing. The machine is simply powered by manual pushing. Therefore, it can be used by both rural as well as urban dwellers. It is also affordable since the cost of production is low. High moisture content and undulated nature of the field surface affected the efficiency of the machine.

Effort should be made to adopt and popularize this design especially for the benefits of rural people who make up a great percentage of the nation's population. It is also hoped that when mass produced the unit cost will be reduced. The cylinder lawn mower is environmental friendly. Finally, a lawn mower gives a fine cut of grass more than any other types of equipment for cutting. With its scissors like mode of cutting, it is the best for lawn.

### REFERENCES

- Grove, L.H.T., 1968. Crop Production Equipment: A Practical Guide for Farmers. Operator Trainee Publisher, Michigan, USA., Pages: 204.
- Ireson, W.G., 1964. Principles of Engineering Economy. 5th Edn., Ronald Press Company Publisher, New York, USA.,.
- John, C., 2012. Fundamental of Machine Design. Lead Printing Press, New York, USA.,.
- Legge, T., 1970. Farm Workshop and Maintenance. Lockwood S & Son Ltd, Fenay Bridge, England, Pages: 95.
- Victor, V.M. and A. Verns, 2003. Design and development of power operated rotary weeder for wetland paddy. J. Agric. Mechanization Asia Afr. Lat. Am., 3: 27-29.
- Walmart, 2011. Home improvements: Lawn mowers. Walmart, Bentonville, Arkansas. <https://www.walmart.com/>.